

**THIS IS A TWO PAGE PARTS LIST.
THIS FIRST PAGE APPLIES TO
MODEL No. 21010805 AT REVISION Q AND LATER REVISIONS**

NO	QTY	PART NO	DESCRIPTION	STD SEAL KIT	FKM SEAL KIT	SPRING KIT
1	1	23050009	WASHER	X	X	X
2	1	23350072	SPRING, COMPRESSION			X
3	1	39010013	SEAL, BEVEL, 9/16 X 3/32 X 3/4	X	39012000	
4	1	39012009	WIPER,PRESS-IN, (1/2)	X	X	
5	1	39055008	GASKET, COPPER	X	X	X
6	1	82110803	PISTON,CYL,CM,2200,.38 STRK,THD			
7	1	39T55005	GASKET, (.753x.080x.080)	X	X	X
N/A	N/A	60210108	KIT, SEAL, CYL, CM, 2200, SA	NOTED	N/A	N/A
N/A	N/A	6V210108	KIT, SEAL, CYL, CM, 2200, SA, FKM	N/A	NOTED	N/A
N/A	N/A	61210316	KIT, SPRING, CYL, CM, 2200, .38 STRK	N/A	N/A	NOTED

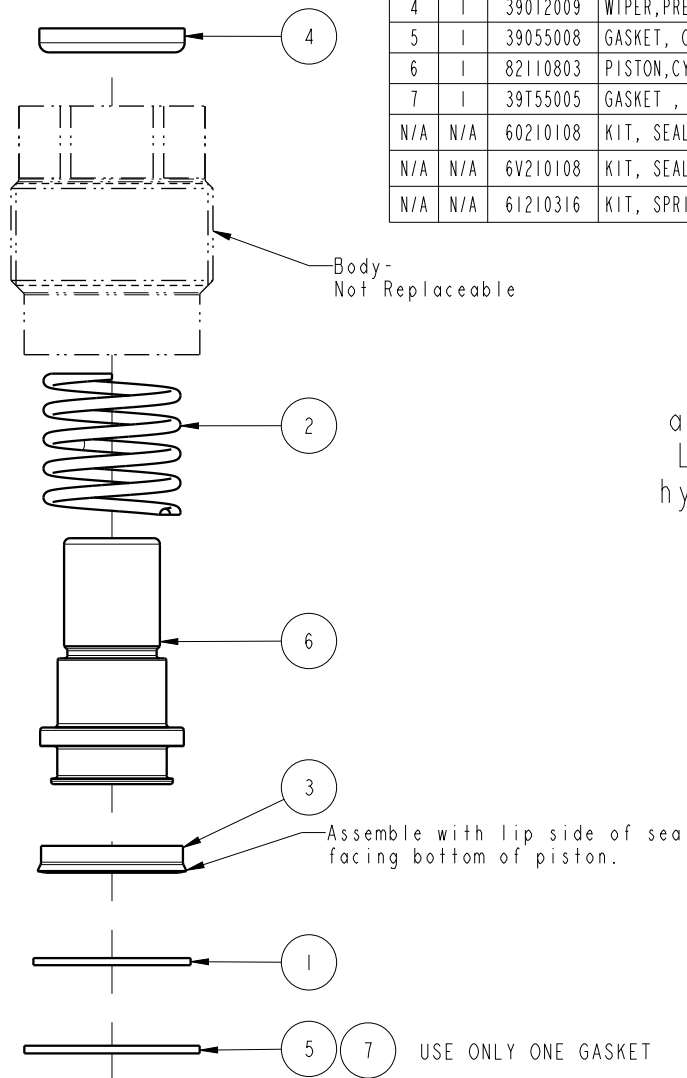

See IS-2100 for machining and installation instructions. Lubricate all seals with clean hydraulic oil prior to assembly. **DO NOT USE SILICONE BASED LUBRICANTS**

INSTALLATION TORQUE:
 -Metal Gasket = 50 ft-lb
 -Composite Gasket = 25 ft-lb
 *Cylinders may need to be re-torqued after a break-in period of 3 weeks or 2,500 cycles for both gasket styles.

Both metal and composite gaskets are supplied. Use only one gasket. The metal gasket is recommended when the cavity seal surface has every smooth finish and is flat and perpendicular to the minor diameter. The metal gasket must be torqued to a higher value, which is more resilient to machining vibrations providing long term sealing. The composite gasket is recommended when the cavity seal surface has a rough surface finish or is not flat.

PARTS LIST	 VEKTEK, INC. 1334 E. SIXTH AVE. P.O. BOX 625 EMPORIA, KS. 66801 U.S.A.	
	ASSEMBLIES AFFECTED	
	21-0108-05 21-0108-05F	
PARTS LIST, ASSY, CYL, CM, 2200, .38 STRK, SA, THD		SIZE A PL2135
DATE: 7-25-97 DRAWING STATUS: Released PRODUCTION APPROVED FOR RELEASED STATUS ONLY		REV P FORM FEG035_PL.ASIZE, REV. B

**THIS IS A TWO PAGE PARTS LIST.
THIS SECOND PAGE APPLIES TO
MODEL No. 21010805 AT REVISION N AND EARLIER REVISIONS**

See IS-2100 for machining
and installation instructions.
Lubricate all seals with clean
hydraulic oil prior to assembly.
**DO NOT USE SILICONE
BASED LUBRICANTS**

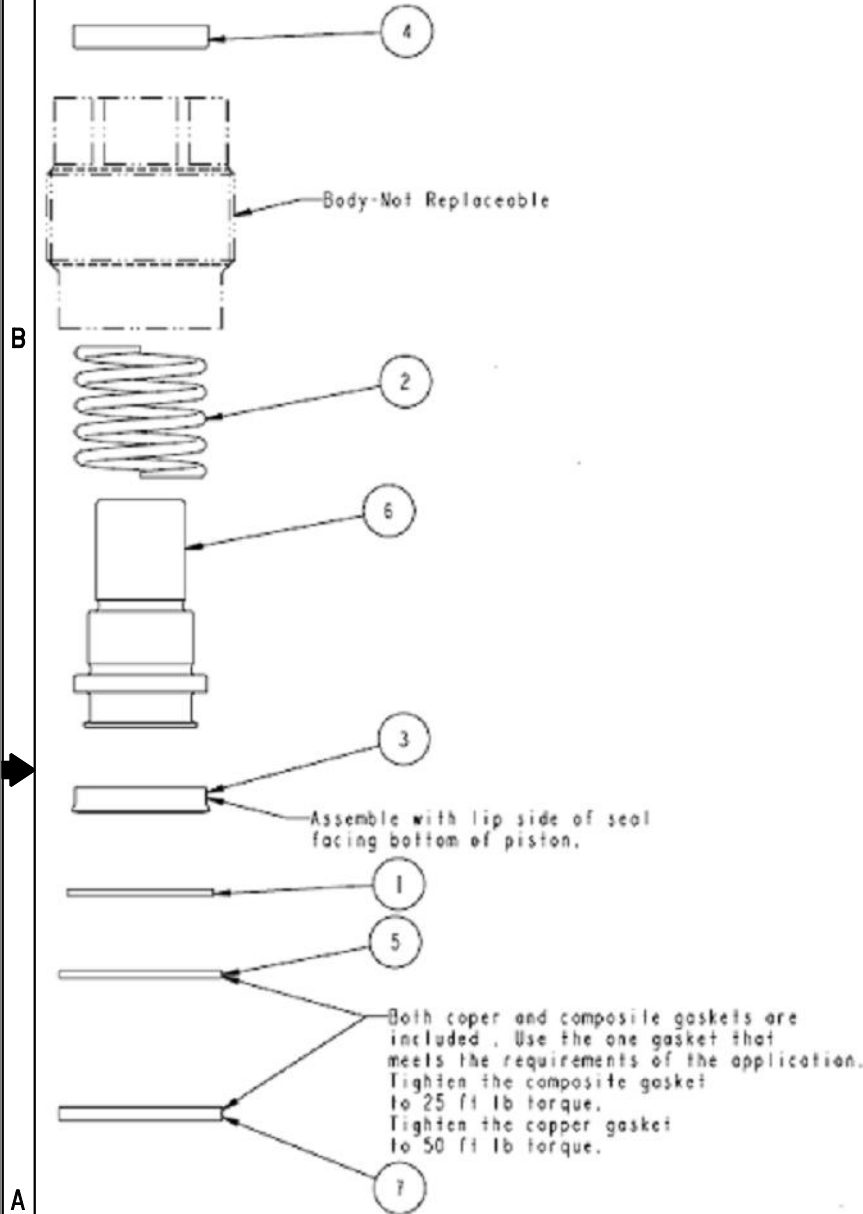

Std Seal Kit 60-2101-08	Fluorocarbon Seal Kit 6V-2101-08	Spring Kit 6I-2103-09
39-T550-05	39-T550-05	39-T550-05
39-0550-08	39-0550-08	39-0550-08
23-0500-09	23-0500-09	23-0500-09
39-0100-13	39-0120-00	23-3130-24
39-0120-09	39-0120-09	

7	1	39T55005	GASKET
6	1	82110801	PISTON, CYL, CM, 2200, .38 STRK, THD
5	1	39055008	GASKET
4	1	39012009	WIPER, PRESS-IN
3	1	39010013	SEAL, BEVEL, 9/16 X 3/32 X 3/4
2	1	23313024	SPRING
1	1	23050009	WASHER
No.	QTY	PART No.	DESCRIPTION

PARTS LIST



VEKTEK
VEKTEK, INC.
1334 E. SIXTH AVE. P.O. BOX 625
EMPORIA, KS. 66801 U.S.A.

ASSEMBLIES AFFECTED	PARTS LIST, ASSY, CYL, CM, 2200, .38 STRK, SA, THD
21010805	
21010805F	
SIZE A	PL2135
REV P	

P	3140	RELEASE	BCD	11/9/16
REV	IN ACCORDANCE WITH ECN	EFFECTIVE DATE	REVISED BY	DATE
DRW BY:	BUSH	DRAWING STATUS: Released		
DATE:	7-25-97	PRODUCTION APPROVED FOR RELEASED STATUS ONLY		

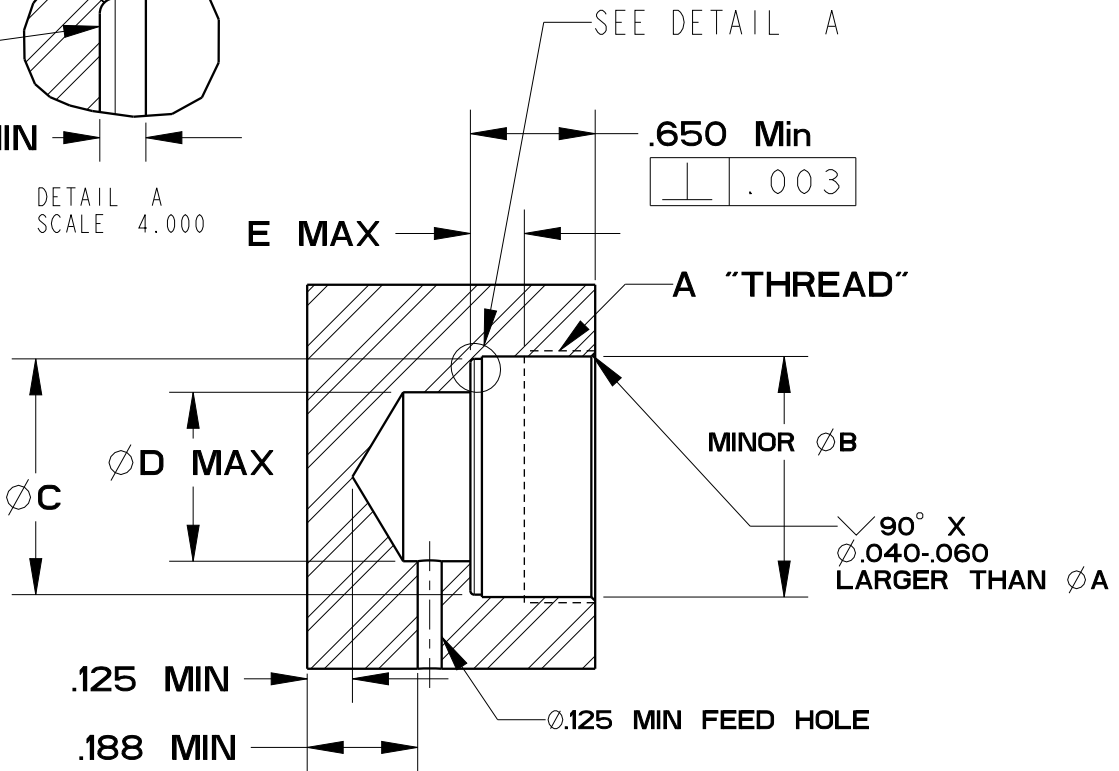
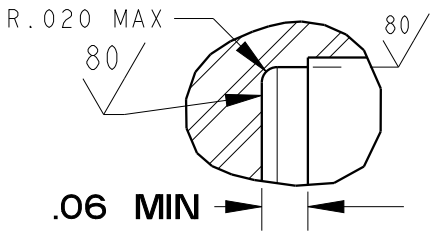

Tighten cylinders with a six point socket only !

Model No.	A	Metal Gasket Torque	Composite Gasket Torque	ØB	ØC	D	E
21-0102-00	3/8-24 UNF-2B	10 ft lb	NA	.335±.003	.325±.005	.13	.100
21-0104-02	5/8-18 UNF-2B	30 ft lb	15 ft lb	.572±.003	.545±.005	.31	.156
21-0105-03	3/4-16 UNF-2B	40 ft lb	20 ft lb	.690±.003	.662±.005	.38	.156
21-0105-04	3/4-16 UNF-2B	40 ft lb	20 ft lb	.690±.003	.662±.005	.38	.156
21-0105-05	3/4-16 UNF-2B	40 ft lb	20 ft lb	.690±.003	.662±.005	.38	.156
21-0105-06	3/4-16 UNF-2B	40 ft lb	20 ft lb	.690±.003	.662±.005	.38	.156
21-0108-04	1 1/16-16 UN-2B	50 ft lb	25 ft lb	1.002±.003	.923±.005	.63	.281
21-0108-05	1 1/16-16 UN-2B	50 ft lb	25 ft lb	1.002±.003	.923±.005	.63	.281
21-0108-08	1 1/16-16 UN-2B	50 ft lb	25 ft lb	1.002±.003	.923±.005	.63	.281
21-0110-04	1 5/16-16 UN-2B	NA	35 ft lb	1.253±.003	1.228±.005	.88	.281

*Cylinders may need to be re-torqued after a break-in period of 3 weeks or 2,500 cycles for both gasket styles.

Instruction Sheet



VEKTEK, INC.
1334 E. SIXTH AVE. P.O. BOX 625
EMPORIA, KS. 66801 U.S.A.

Model number -See Chart-

Cavity Dimensions

Cartridge Mounted Cylinders

SIZE A **IS-2100** REV G

G	3041	RELEASE	BCD	11/9/16
REV	IN ACCORDANCE WITH ECN	EFFECTIVE DATE	REVISED BY	DATE
DRW BY:	VANDALSEM			
DATE:	04-13-93			
DRAWING STATUS: Released PRODUCTION APPROVED FOR RELEASED STATUS ONLY				